



# Updated Briefing & Guidance on Considerations for the Ventilation Aspects of Healthcare Facilities for Coronavirus – Updated 24<sup>th</sup> March 2020

Revision Number 3.3 (24-03-2020)

## Acknowledgments

Lead Author - Andrew Poplett IEng, MSVHSoc, MIHEEM, ACIBSE, AffIFE

The following individuals and organisations were consulted during the preparation of this document. Their contribution is gratefully acknowledged.

- Graham P. Taylor BSc, PGDip, FIHEEM, MIET, MWMSoc
- Members of the Specialist Ventilation for Healthcare Society

© The content of this document may be freely reproduced and used providing the source is acknowledged as being the Specialised Ventilation for Healthcare Society (SVHSoc.).

## Introduction

Following a review and advice from Public Health England (Peter Hoffman) the briefing and guidance from the SVHSoc has been updated to reflect the current official guidance and to provide a range of options and areas for consideration for healthcare estates professionals to provide enhanced levels of protection for patients, staff, and visitors.

The briefing is intended to provide an overview of the issues and points to consider when assessing the ventilation strategy and options. It has also been updated to provide some initial maintenance considerations and precautions which may need to be considered. It is intended that this briefing and guidance will be subject to regular review and updates as details, information, and the situation continues to develop.

Current guidance on the lifespan of the virus once outside the body is still to be fully established, however current estimates are that it could survive anywhere between a few hours up to 3 to 4 days on hard surfaces and is spread by both primary direct exposure (breathing in droplets expelled from an infected person from coughing or sneezing) and secondary contact by touch (touching a surface which has been contaminated and transferring this contamination by touch to the mouth, nose or eyes). "Coronaviruses are mainly transmitted by large respiratory droplets and direct or indirect contact with infected secretions. They have also been detected in blood, faeces and urine and, under certain circumstances, airborne transmission is thought to have occurred from aerosolised respiratory secretions and faecal material". That level of airborne transmissibility is specifically associated with certain aerosol generating procedures (AGPs).

That COVID-19 has been termed an airborne infection is an indication that it is capable of transmitting via an airborne route in certain circumstances, not that its mode of spread is primarily airborne nor that any aerosol remains sufficiently concentrated to be infectious over longer distances other than in the immediate vicinity of a dispersing patient.

The PHE guidance is under constant review and updated as necessary. The current guidance can be found at:

<https://www.gov.uk/government/publications/wuhan-novel-coronavirus-infection-prevention-and-control>

Ventilation can contribute to an isolation or protection strategy to assist in minimising the spread of the virus, however a number of factors need to be considered, not least of all the provision of adequate ventilation to provide dilution of any airborne contamination, with other factors including;

- Area / rooms where isolation can be established
- Physical / fabric of the room construction / air permeability rates (e.g. solid ceilings)
- Surrounding areas of clinical activity
- Room volume and airflow / room pressure differentials (dilution effects)
- Provision and location of ventilation (e.g. ceiling mounted supply with low level extract)
- Point of discharge of any extracted air and filtration of same
- Levels of isolation and practical considerations
- Decontamination of the area between patients
- Protection of all potentially exposed staff groups (clinical, cleaning, and estates)

### Standards and Technical Specifications

HTM 03-01 sets out the overall guidance for ventilation of healthcare premises with addition specific guidance on isolation facilities being contained within HBN 04-01 Supplement. These documents should be used as the basis for all ventilation strategies in conjunction with advice from the Infection Prevention Control (IPC) team, WHO & PHE support. Overall it needs to be an issue where IPC set the room criteria and then estates can look to see how it can be provided.

*Note/commentary from PHE - Standards and technical specs; We (PHE) are rapidly moving to a position where COVID patients will be cohorted on bays in wards. Beyond specific “aerosol generating procedures” (AGPs) there is not thought to be an airborne risk and staff do not require respirators. This can be seen from the “general ward” guidance for AGPs in the PHE guidance.*

*Table 1: Transmission based precautions (TBPs): Personal protective equipment (PPE) for care of patients with pandemic COVID-19*

	<i>Entry to cohort area (only if necessary) no patient contact*</i>	<i>General ward *</i>	<i>High risk unit ICU/ITU/HDU</i>	<i>Aerosol generating procedures (any setting)</i>
<i>Disposable Gloves</i>	<i>No</i>	<i>Yes</i>	<i>Yes</i>	<i>Yes</i>
<i>Disposable Plastic Apron</i>	<i>No</i>	<i>Yes</i>	<i>Yes</i>	<i>No</i>
<i>Disposable Gown</i>	<i>No</i>	<i>No</i>	<i>No</i>	<i>Yes</i>
<i>Fluid-resistant (Type IIR) surgical mask (FRSM)</i>	<i>Yes</i>	<i>Yes</i>	<i>No</i>	<i>No</i>
<i>Filtering face piece (class 3) (FFP3) respirator</i>	<i>No</i>	<i>No</i>	<i>Yes</i>	<i>Yes</i>
<i>Disposable Eye protection</i>	<i>No</i>	<i>Risk assessment</i>	<i>Risk assessment (always if wearing an FFP3)</i>	<i>Yes</i>

**Notwithstanding the above, in the SVHSoc's opinion, a standard for any facility used, should strive to achieve the following performance criteria;**

- The room ideally should be neutral or negative to the surrounding areas (-5 to -10 Pa)
- The room should achieve between 6 to 12 air changes per hour
- If achievable the room should have sufficient air supply and extract to achieve open door protection, however this may not be possible other than in a PPVL room.
- The room should ideally have a protected lobby (if possible) with barrier nursing and PPE worn by all staff
- Immediately outside but adjacent to the room there should be a wash hand basin and an area for de-gowning. If the room has a lobby (PPVL) then de-gowning should take place within the lobby.

### **General Options and Considerations**

A negative pressure or PPVL room with lobby is the likely preferred locally achievable option. Extract filtration is not likely to be required as it is likely to significantly impact on the airflow performance and it will be necessary to undertake a risk based assessment on the use of extract filtration and consider system upgrades to maintain overall airflow performance. The point of discharge of any extract ventilation system should be assessed to ensure that it does not provide a route of cross contamination.

If however multiple PPVL rooms are not available then a side room with a lobby and its own en-suite is likely to be the next best option. The extract from the en-suite will provide some degree of pressure cascade / regime although it is unlikely to provide open door protection and the point of discharge location will again require to be assessed. If a side room has supply air then this should be re-balanced to provide a minimum fresh air rate but be less than the extract air volume to maintain the room at a negative pressure, whilst not compromising dilution effect. Negative pressure units (NPU) are readily available in the asbestos removal industry, they come with DOP test HEPA filters and could be considered to create a negative pressure room on a temporary basis.

If an air scrubber/filtration unit is considered it will not provide any dilution or fresh air supply into the room, but may remove some contamination from the air, however the issue of how to de-contaminate and dispose of the filter unit between patients will need consideration (see maintenance considerations below).

As the spread of the virus continues it is likely that hospitals will be asked to identify and consider designating entire ward areas or even buildings as isolation facilities. This cohorting of cases will be driven by clinical risk assessment based upon risk of cross contamination (between patients within the isolation space) and the need for clinical support/treatment. In these circumstances it is likely that the capacity of the electrical and medical gas infrastructure (oxygen, medical air, and vacuum) systems will be the greatest challenge and ventilation will be a secondary issue, however some basic principles should be considered;

- Wards with single bedrooms with en-suite facilities are likely to offer the best solution.
- The extract rate should be greater than the supply where practical, to create a negative pressure cascade to surrounding areas, ideally with supply in corridors and extract by means of en-suite facilities and dirty extract systems, in all cases ward doors to circulation spaces MUST be kept closed as far as reasonably practical.
- Maintaining a good air change rate of between 6 - 12 ACH is considered appropriate to maintain a dilution effect for both patients and staff protection.

- If open plan/multi-bed bay wards are used then a clinical assessment of risk relating to cross contamination will be needed, however areas with low level extract by each bed space would be preferable.
- If the ventilation system (AHU) serves more than a single ward then the supply aspect is less critical as the airflow direction provides a level of protection, however an ACR of around 6 ACH should be considered as a minimum. Shared extract systems are less ideal and consideration should be given to separating or closing off non-essential extracts if practical. Extract systems should be inter-locked with supply systems to ensure that if the supply fails the extract continues to operate, however if the extract fails then the supply should also switch off, only as a short term measure until the extract system can be repaired / re-instated. If a failure is likely to be over 1 hour then the supply can be reinstated to provide both thermal comfort and dilution provided that it does not create a cross contamination risk.
- If an area or room is identified as being potentially suitable to be used as a temporary isolation facility it is advisable if possible to undertake a 'room air permeability or leakage test' to ensure air is contained within the room and does not leak to adjacent areas through suspended ceiling or service penetrations, (this may not be practical to achieve, given the urgency of demand).
- Any room used as a temporary holding or isolation facility should be stripped of all non-essential materials and soft furnishings.
- If you can locate an increased extract unit to provide a negative pressure environment then care will be needed when considering the distribution ducting and the exhaust air discharge point. Ducting and extract grilles should be located to ensure an even draw of air from around bed spaces and not rely on a single point at the end of the unit which draws air over adjacent patients and staff. The exhaust discharge however providing it is discharging to a safe external space (ideally at high level 3m above roof level) then HEPA filtration is unlikely to be required. Consider sealing any openable windows in the immediate vicinity (around 4m) of any low level discharges and avoid discharge over pedestrian paths/walkways.

### **Use of Theatres as CCU's**

As the need for critical care beds increases hospitals will need to identify areas which are suitable and have the required engineering and medical services to provide an appropriate and safe clinical environment. In many cases where patient ventilation / life support is required the theatre and associated recovery suites (freed up from elective procedures from mid-April) could be considered as ideal. If kept for the exclusive use by non-infected patients the ventilation system is likely to need little modification or adjustment, however consideration may be given to lowering both supply and extract rates to save energy and ensure patient comfort (reducing ACRs to around 10 ACH would be appropriate). Typically 2 CCU bed spaces could be provided per theatre with an addition bed located in the anaesthetic room if needed, (medical gases, adequate ventilation and electrical outlets are typically all present in these rooms). Recovery spaces are designed to provide 12-15 ACH and should be neutral to surrounding areas so no modifications to the ventilation system should be needed.

If it is proposed to use theatres as spaces to treat COVID 19 infectious patients then the airflows would need to be very carefully reviewed and adjusted to maintain a safe air change rate and provide an ideally neutral pressure regime to surrounding clinical and staff areas.



## Use of Theatres for COVID 19 infected patients Including Emergency Maternity Theatres

The following information reflects the current guidance from the centre for the use of theatres for known or suspected infected (COVID19) patients;

<https://www.gov.uk/government/publications/wuhan-novel-coronavirus-infection-prevention-and-control>

### 18. Theatres

- theatres must be informed in advance of a patient transfer of a confirmed or possible COVID-19 positive case
- the patient should be transported directly to the operating theatre and should wear a surgical mask if it can be tolerated
- the patient should be anaesthetised and recovered in the theatre. Staff should wear protective clothing but only those at risk of exposure from aerosol generating procedures, ie during intubation need to wear FFP3 respirators and full gowns. considerations about the use of respiratory/anaesthetic equipment are addressed in the critical care section above
- instruments and devices should be decontaminated in the normal manner in accordance with manufacturers' advice
- both laryngoscope handle and blade should either be single use or reprocessed in the Sterile Supply Department. Video laryngoscope blades should be single use and scope/handle decontaminated as per manufacture instructions.
- instruments must be transported safely to decontamination, following use
- the theatre should be cleaned as per local policy for infected cases, paying particular attention to hand contact points on the anaesthetic machine
- theatres should not be used by staff or patients for 20 minutes after the patient leaves if conventionally ventilated, or 5 minutes if ultraclean ventilation is used
- possible or confirmed cases of COVID-19 should be placed at the end of the list where feasible

The follow information is provided to support or supplement this initial guidance.

### Neutral Pressure Theatres

With the current COVID19 infection issues there may be a requirement for an operating suite to be used for an infected or suspected patient. If airborne micro-organisms liberated from a patient during the surgical procedure are allowed to cascade out into the adjacent corridors, they could contaminate surfaces or infect other patients or the staff within the surrounding operating department.

The concept of a neutral pressure or infectious theatre is to maintain an appropriate and safe air change rate to the theatre space but instead of the tradition cascade arrange of air from the theatre suite to the surrounding areas it is a based on a balanced air flow of both supply and extract from ideally within the theatre itself or as a minimum within the individual theatre suite.

The room provision and layout will be as for a conventional operating suite with the following variation to the ventilation scheme:

- The operating theatre will have a balanced supply and extract so that it is at the same pressure as the corridor.
- Air should not cascade from the theatre to the surrounding rooms so pressure stabilisers and / or transfer grilles will not be fitted.

- The preparation room could be dispensed with to avoid having stock that could become pre-contaminated. Sterile packs, instruments and consumables would be delivered to the theatre on a case by case basis. If a preparation room is required, then it should be maintained at 10Pa to both the theatre and corridor.
- The anaesthetic room should have a supply in excess of extract so that is maintained at 10Pa above both the corridor and theatre. There should be a pressure stabiliser between the anaesthetic and corridor but no transfer between the anaesthetic and theatre.
- The scrub should have an active extract as for a conventional operating suite but no pressure stabiliser between it and the corridor.
- The utility should be at -5Pa to the theatre and its corridor.
- The corridor extract will be sized to cater for the air leakage from the anaesthetic room only.

Overall the ventilation scheme should ensure that all air supplied to the operating theatre is removed in the theatre suite. The theatre should be neutral (at the same pressure) to the corridor so that when the theatre exit door is open there is effectively no interchange of air between them. Ideally when the preparation or anaesthetic doors are opened airflows from them into the theatre and not the other way.

The traditional theatre suite layout typically as below (or a variation thereof);

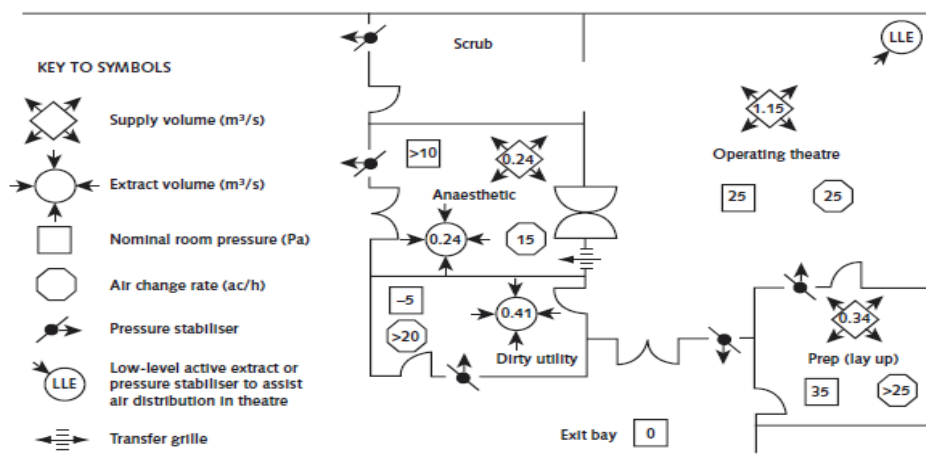

If sites are required to endeavour to transform existing positive pressure cascade theatres to create a neutral pressure theatre the following areas will need to be considered.

In line with guidance the patient should be brought into and out of the theatre through the anaesthetic room, but anaesthetised and recovered in theatre. The doors and any pressure stabilisers from the theatre to the corridor should be sealed and not used.

The lay-up prep area should only hold the minimum stock required for the given procedure, however the air cascade from the lay-up prep to theatre should be maintained as a positive differential.

The pressure stabilisers from both the scrub area to the corridor and the anaesthetics room to corridor should be sealed.

The dirty utility room should remain at a negative pressure differential to both the theatre and corridor.



Ideally the anaesthetics room should be neutral pressure to the theatre, however this may not be practical, in which case the anaesthetics room should only have all surfaces as clear as practical and all surplus or spare equipment held elsewhere.

A full re-balance of the supply and extract systems will be required and the provision of addition theatre extract is also likely. This will have to be assessed and designed on a theatre by theatre basis.

The same considerations apply to both conventional and UCV theatres. The UCV canopy is a re-circulation canopy and as such should have minimal impact on the theatres pressure regime, however due care should be taken not to disturb the canopies clean airflow area with excessive localised air movement and prevent perturbation of the UCV canopy air pattern.

It may be necessary to consider a relaxation of minimum air change rates to achieve a neutral pressure cascade however these should not be lower than 18ACH and MUST be agreed with clinical and IPC teams based on clinical risk assessment.

All non-essential materials and equipment should be removed from the theatre and surrounding corridor areas to ensure all cleaning can be undertaken as easily as possible.

Specific patient and staff procedures and flows will need to be considered and agreed.

An alternative approach may be to designate a suite of theatre suites within a single location (floor or building) as infectious at which point the entire theatre complex could be isolated from any surrounding clinical areas and used exclusively for only infectious patients. In this case provided the extracted air was discharged to a safe location and all staff wear PPE whenever within the theatre area no or limited modification to ventilation strategies would be necessary.

## **Summary**

Any healthcare organisation which is undertaking this assessment or provision should seek to obtain specialist advice both internally from the organisations own multi-disciplinary team (estates (AP(V), IPC, Clinical leads, Decontamination leads, Medical Gas AP(MPGS), etc...) but also from an appropriately qualified and experienced Authorising Engineer (Ventilation) or other suitable professional design consultant.

## Non ventilation Considerations

In addition to the ventilation issues associated with the current COVID 19 pandemic, other healthcare related engineering services and operational considerations will need to be assessed and considered. These are likely to include;

- Medical gas capacities and flow rates to deliver required clinical treatments (oxygen, medical air & vacuum).
- Number and location of electrical outlets on essential power supplies, for clinical and medical electronics.
- Provision of suitable emergency lighting
- Patient access and egress / transportation routes through other clinical / public areas.
- A minimum separation distance of between 1 – 2 metres should be maintained between beds
- If temporary separation / partition walls or barriers are constructed to create segregated bed spaces, the fire strategy and fire evacuation plans MUST be reviewed to ensure they remain appropriate. This should involve identification of evacuation routes and places to provide both an immediate safe refuge and a place to continue care and treatment.
- Provision of adequate hand washing facilities.
- Waste collection and storage capacities and locations and transfer routes.
- Surrounding clinical services to avoid close proximity to other 'at risk' patient groups.
- Adequate staff welfare and rest areas if staff numbers are increased to meet clinical needs.

Estates staff are recommended to give consideration to all of the above and where considered necessary review the PHE guidance and consult with their appropriate Authorising Engineer for the associated engineering specialty.

Additional guidance is available in the NHS&I – Novel coronavirus (COVID-19) standard operating procedure – Design Note: COVID-19 ward for intubated patients version 1.0 published 22/03/2020 (Publications approval ref 001559).



## Ventilation Maintenance Considerations

### Ventilation breakdowns and repairs

Any potential contamination risk associated with extract ductwork, fans and filters is likely to be very low. The ventilation system acts to dry out any droplets that are drawn out of a room and if these droplets settle on ductwork or fan surfaces they will very quickly desiccate and are likely to be inactive. Notwithstanding this it is advised that enhanced precautions should be taken by maintenance staff when working on such systems both as a precautionary measure and to provide re-assurance to those undertaking the work.

If a breakdown or internal inspection is required to an extract system from a potentially contaminated area then the following issues should be considered;

- Minimise the tools taken into the area during any period when a system is 'opened up' for maintenance or inspection.
- Following work being completed old or redundant materials / components should be bagged and removed as clinical waste.
- Tools used during the work should be washed / disinfected where practical or wiped down with alcohol based steri-wipes or similar.
- Minimise the number of workers in the immediate area of the work, whilst maintaining safe working conditions and staffing levels (two man working may be necessary if working at height or if moving and handling issues exist).
- All staff should wear appropriate PPE and dress, remove, and dispose of it as detailed below.

Other maintenance activities not directly relating to extract ventilation maintenance such as fire damper drop testing, or ductwork cleanliness inspections will need to be managed so as to ensure that no potential contaminated extract ductwork is opened accidentally. Smoke and fire dampers on extract systems will need to be assessed to ensure routine fire alarm testing does not interrupt or involve extract ductwork ventilation system operation, if being used for isolation protection.

The precautions and method statement detailed above should be adapted / applied to all maintenance staff working in areas where potentially or known infectious patient are or have been located whether working on ventilation systems or any building / estates related element / equipment.

### Filter changing

There are two typical types of filters installed in extract ventilation systems, Safe change types in systems designed to handle toxic or contaminated air (LEV's or HCID units) also known as Bag In Bag Out BIBO type filter units and general filtration (primarily designed to protect fan components and heat exchangers).

Safe change filter units as specifically designed to enable removal and replacement without exposing the maintenance worker to direct contact with the dirty filter. The design of these units can vary so the manufacturers' guidance notes and method statements should be followed to ensure safe removal and disposal.

General filters will not be of a grade that is designed to capture all particles, but will capture some and should be treated carefully. Prior to opening up a unit to remove a general filter a disposal bag should be available. The unit should be switched off and any backflow dampers allowed to close (or if manual – closed) prior to opening up the filter access door. The filter should be removed carefully to minimise the release of any dust/contamination on the filter surfaces and placed directly into the disposal bag.



The filter frame should be cleaned ideally with a HEPA filter vacuum cleaner or wiped down with an alcohol based steri-wipe, the used wipes should also be disposed of in the filter disposal bag.

Once clean the new replacement filter can be installed, the unit re-assembled and the fan switched on, once any manual dampers have been re-opened.

## **PPE**

Putting on and removing personal protective equipment

Putting on PPE

Before donning, healthcare maintenance workers should, remove all nonessential items and tools from overalls and tool bags, ensure they are hydrated, and perform hand hygiene.

Staff should wear the following PPE, put on in the following order:

- Disposable boiler suit/coveralls
- FFP3 respirator and fit check
- eye protection (goggles or face shield)
- disposable gloves

The order given above is practical but the order for putting on is less critical than the order of removal given below. During donning each item must be adjusted as required to ensure it fits correctly and interfaces well with other PPE items.

Removal of PPE

PPE should be removed in an order that minimises the potential for cross-contamination.

If working within a clinical space after leaving the side room gloves, disposable boiler suit and eye protection should be removed (in that order, where worn) and disposed of as clinical waste. The respirator can be removed and the filters disposed of as clinical waste with the mask being wiped clean with alcohol based steri-wipes or similar.

If working in a plantroom or service area (on remote located ventilation equipment associated with an isolation facility) then the PPE should be removed and bagged prior to leaving the plantroom area. Other staff should not be working in the area whilst the maintenance work to extract ventilation systems is being undertaken.

The order of removal of PPE is suggested as follows, consistent with WHO guidance:

- peel off gloves and dispose in clinical waste
- perform hand hygiene
- remove boiler suit by using a peeling motion, fold in on itself and place in clinical waste bin
- remove goggles or visor only by the headband or sides and dispose in clinical waste
- remove respirator from behind and dispose of filters as clinical waste
- Clean respirator mask housing using alcohol based steri-wipes or similar.
- perform hand and face hygiene

For additional guidance see the PHE COVID-19: Guidance for infection prevention and control in healthcare settings. Version 1.0. Appendix 3 – Best Practice - Putting on and taking off PPE.



## References

Health Technical Memorandum 03-01 Specialised ventilation for healthcare premises Parts A & B (2007)

Health Building Note 04-01 Supplement 1 Isolation facilities for infectious patients in acute settings

2007 Guideline for Isolation Precautions: Preventing Transmission of Infectious Agents in Healthcare Settings - *Jane D. Siegel, MD; Emily Rhinehart, RN MPH CIC; Marguerite Jackson, PhD; Linda Chiarello, RN MS; the Healthcare Infection Control Practices Advisory Committee*

Guidance Wuhan novel coronavirus (nCoV) infection prevention and control guidance Updated 31st January 2020 - Gov.UK Public Health England

Guidance COVID-19: infection prevention and control guidance PHE.Gov.UK

NHS&I – Novel coronavirus (COVID-19) standard operating procedure – Design Note: COVID-19 ward for intubated patients version 1.0 published 22/03/2020 (Publications approval ref 001559).

COVID-19 Guidance for infection prevention and control in healthcare settings Adapted from Pandemic Influenza: Guidance for Infection prevention and control in healthcare settings 2020 Issued jointly by the Department of Health and Social Care (DHSC), Public Health Wales (PHW), Public Health Agency (PHA) Northern Ireland, Health Protection Scotland (HPS) and Public Health England as official guidance.